

Series GSU



AVENTICS™ Series GSU



Guided slide unit, Series GSU

- Ø 16-25 mm
- Ports M5 G 1/8
- double-acting
- with magnetic piston
- mini ball rail guide ball rail guide
- Cushioning hydraulic non-adjustable
- Easy2Combine capable
- adjustable end stops



Working pressure min./max.	See table below
Ambient temperature min./max.	0 ... 60 °C
Medium	Compressed air
Max. particle size	5 µm
Oil content of compressed air	0 ... 1 mg/m ³
Pressure for determining piston forces	6.3 bar
Weight	See table below

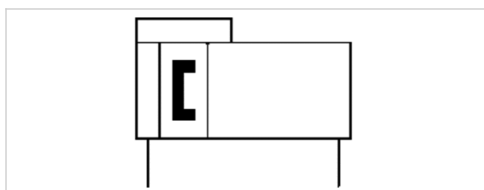

Technical data

Piston Ø	16 mm	25 mm
Stroke 200	R402000986	R402000995
300	R402000987	R402000996
400	R402000988	R402000997
500	R402000989	R402000998
600	R402000990	R402000999
700	R402000991	R402001000
800	R402000992	R402001001
900	R402000993	R402001002
1000	R402000994	R402001003

Stroke length adjustable and end stops can be mounted over the entire stroke.

Technical data

Piston Ø	16 mm	25 mm
Piston force	127 N	309 N

Piston Ø	16 mm	25 mm
Cushioning length	10 mm	12.5 mm
Cushioning energy	2.3 J	3.3 J
Speed max.	1.5 m/s	1.5 m/s
+10 mm stroke	-	-
Stroke max.	1000 mm	1000 mm

Technical information

The pressure dew point must be at least 15 °C under ambient and medium temperature and may not exceed 3 °C .

The oil content of compressed air must remain constant during the life cycle.

Use only the approved oils from AVENTICS. Further information can be found in the "Technical information" document (available in the MediaCentre).

Technical information

Material	
Cylinder tube	Aluminum, anodized
Cap	Aluminum, anodized
Seal	Polyurethane
Sealing strips	Polyurethane Stainless steel
Ball rail table	Aluminum, anodized
Guide shuttle	Stainless steel Steel
Guide rail	Stainless steel, hardened Steel, hardened

Dimensions

Dimensions

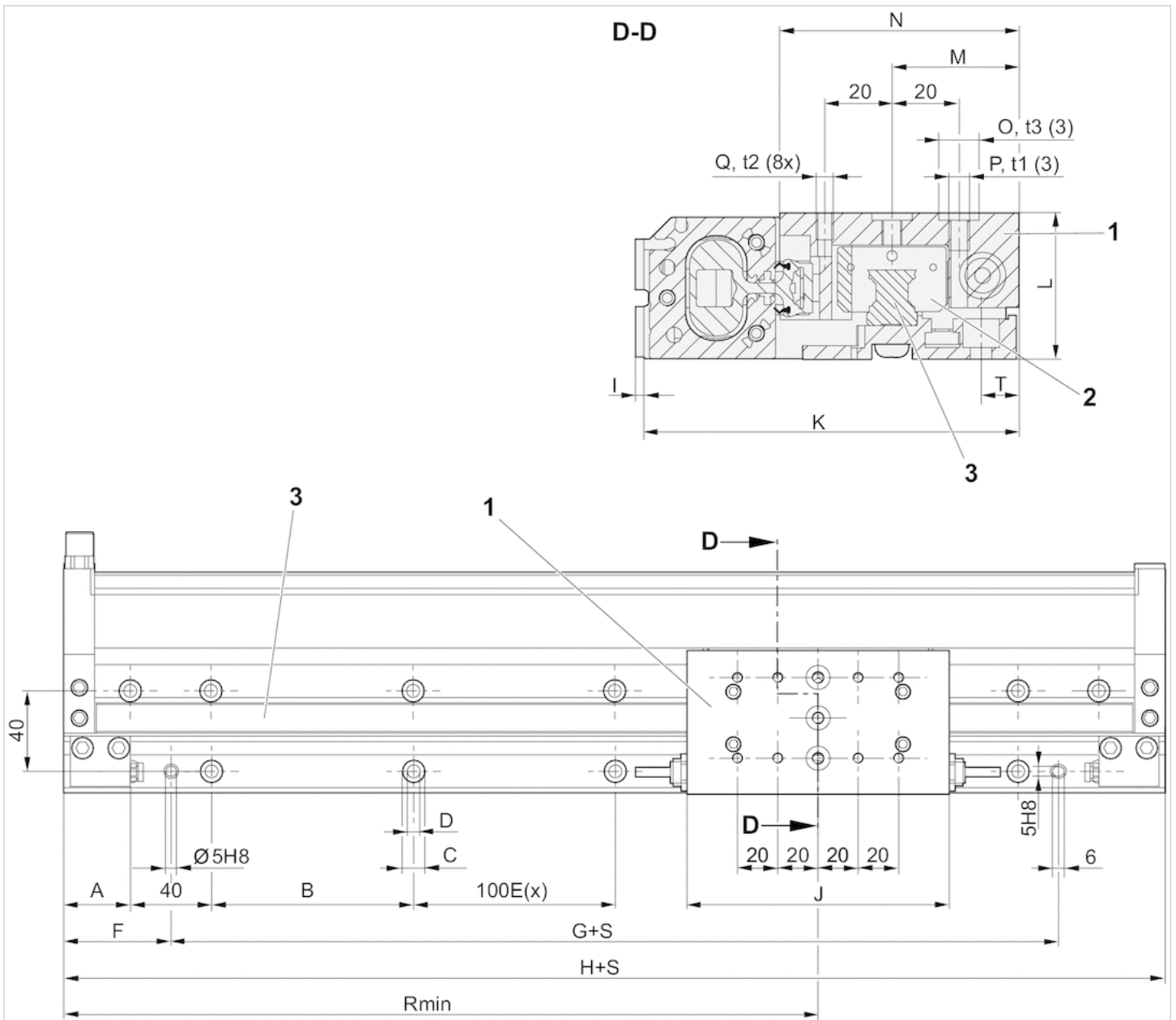

- S = stroke
- t1, t2 = depth of thread
- t3 = sinkhole depth
- 1) Ball rail table
- 2) Guide shuttle
- 3) Guide rail

Dimensions

Piston Ø	A	B	C	D	F	G	H	I	J	K	L	M	N	O	t3	P
16 mm	25	92	Ø 9,5	Ø 5,5	45	124	214	3.6	110	99	29	33.5	69	Ø 9 H8	2,1 +0,2	M5
25 mm	33	100	Ø 11	Ø 6,6	53	140	246	2.5	130	111.65	43.5	37.85	71.15	Ø 12 H8	2,1 +0,2	M6

Piston Ø	t1	Q	t2	R 1)	T
16 mm	9	M4	8	107	7.5
25 mm	9	M5	8	123	11.35

1) Min.

Weight [kg]

Piston Ø	Stroke	200	300	400	500	600	700	800	900	1000
16 mm	E(x)	1	2	3	4	5	6	7	8	9
25 mm	E(x)	1	2	3	4	5	6	7	8	9

Stroke-dependent dimensions

Piston Ø	Stroke	Weight kg
16 mm	200	1.78 kg
16 mm	300	2.09 kg
16 mm	400	2.4 kg
16 mm	500	2.71 kg
16 mm	600	3.02 kg
16 mm	700	3.33 kg
16 mm	800	3.64 kg
16 mm	900	3.95 kg
16 mm	1000	4.26 kg
25 mm	200	3.21 kg
25 mm	300	3.73 kg
25 mm	400	4.25 kg
25 mm	500	4.77 kg
25 mm	600	5.29 kg
25 mm	700	5.81 kg
25 mm	800	6.33 kg
25 mm	900	6.85 kg
25 mm	1000	7.37 kg

Dimensions

Permissible forces F_x , F_y , F_z and torques M_x , M_y , M_z , static

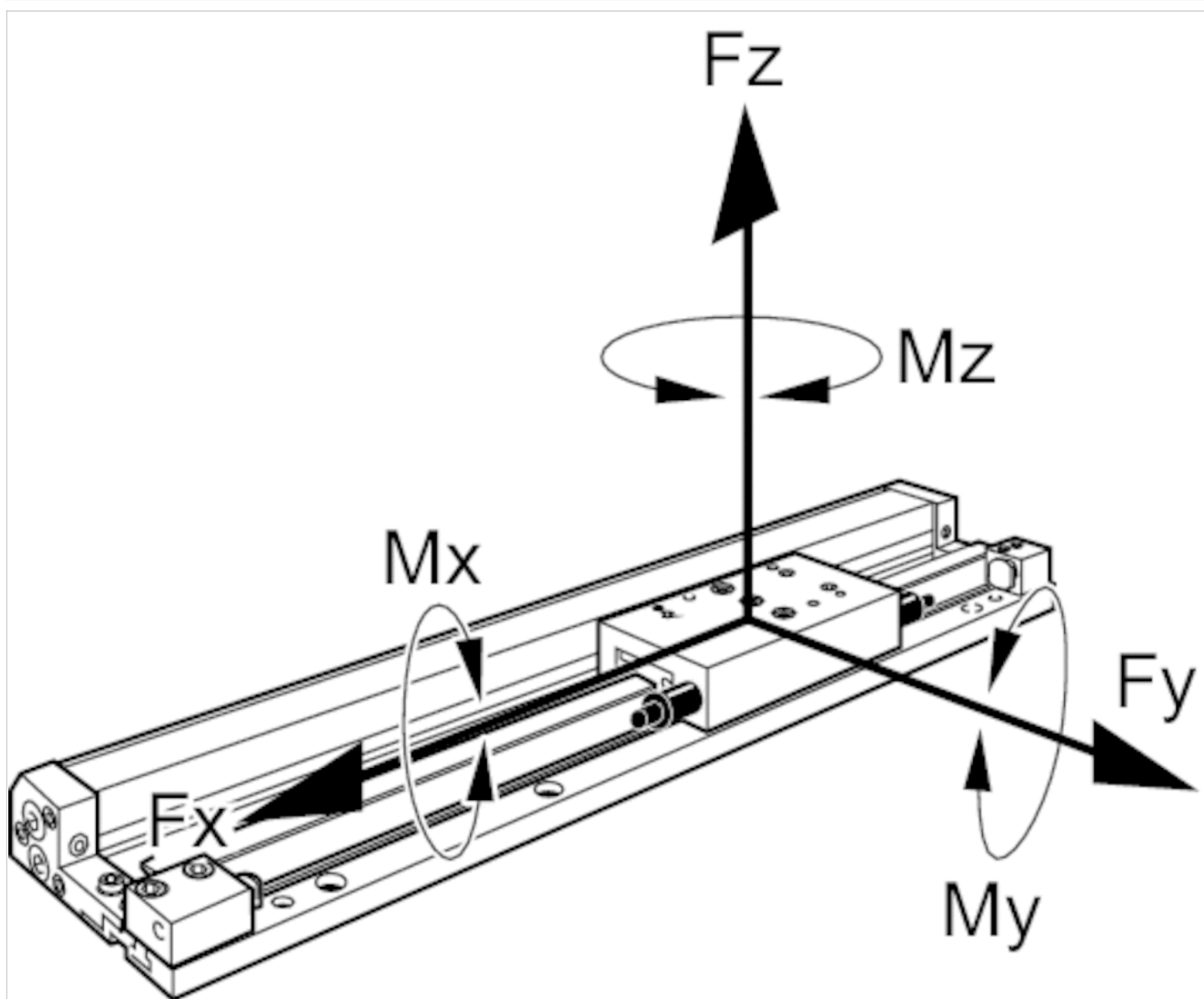

Dimensions

Piston \varnothing	F_x [N]	F_y [N]	F_z [N]	M_x [Nm]	M_y [Nm]	M_z [Nm]
16 mm	880	880	1500	20	40	40
25 mm	1070	1070	2500	55	65	65

Dimensions

dynamic

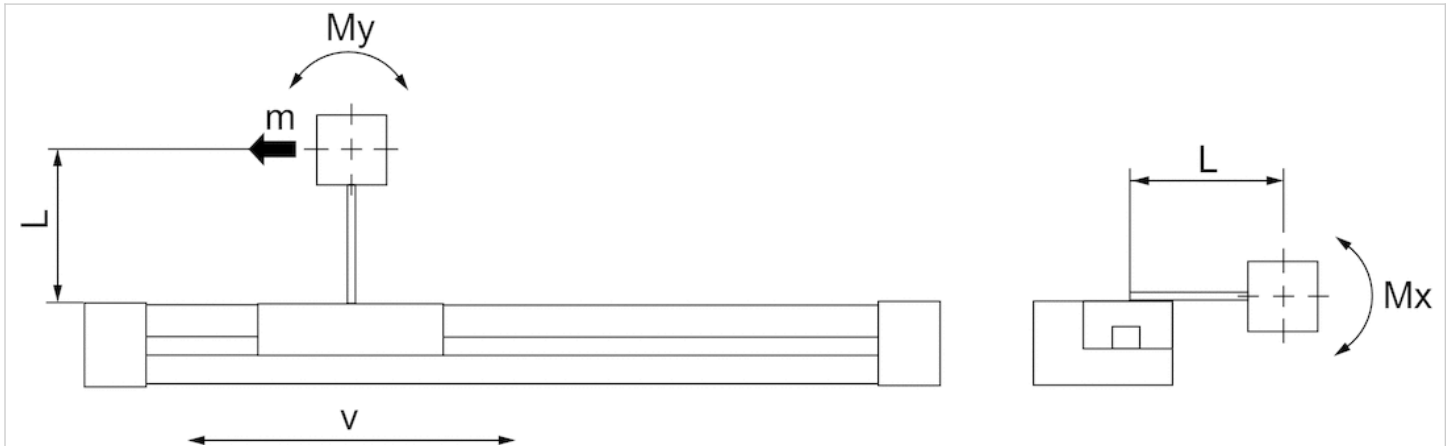

L indicates the distance between the mounting plate center and the center of mass of the attached parts.

Diagrams

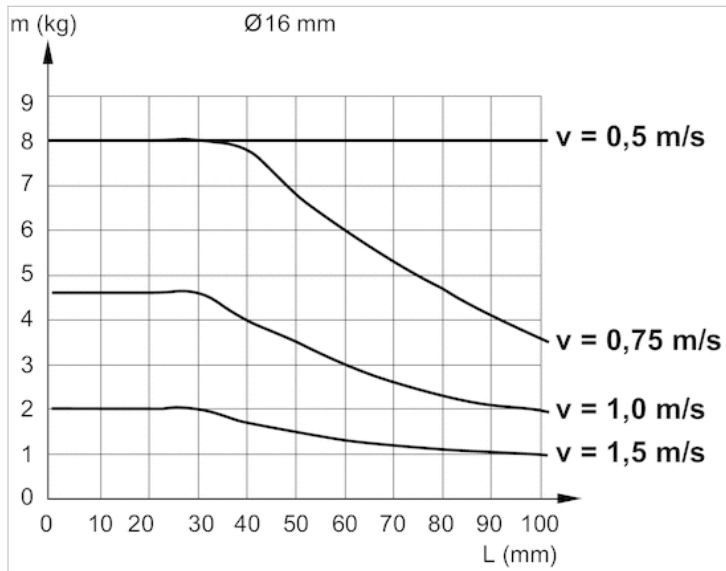

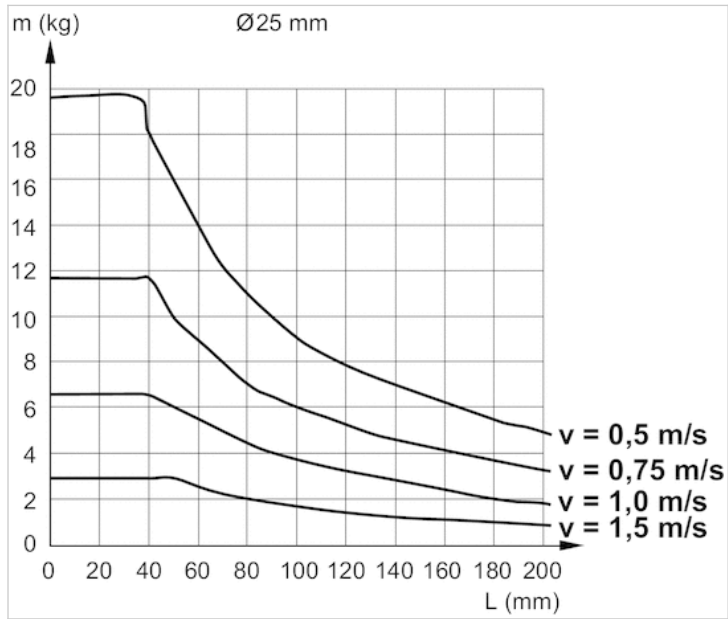

Sensor, Series ST4

- 4 mm T-slot
- with cable
- Plug, M8, 3-pin, with knurled screw
- UL certification
- Reed electronic PNP
- Direct mounting for series PRA, SSI, GSU, RTC, CKP, GPC, MSC, MSN, RCM, CVI
- Indirect mounting for series MNI, CSL-RD, ICM



Certificates	UL (Underwriters Laboratories) cULus RoHS
Ambient temperature min./max.	-30 ... 80 °C
Protection class	IP65, IP67
Switching point precision	±0,1 mT
Min./max. DC operating voltage	See table below
Switching logic	NO (make contact)
Display	LED
LED status display	Yellow
Vibration resistance	10 - 55 Hz, 1 mm
Shock resistance	30 g / 11 ms
Cable length L	0.3 0.5 m
Mounting screw	Combination: slotted and hexagon socket

Technical data

Part No.		for
R412019490		PRA, SSI, GSU, RTC, CKP, GPC, MSC, MSN, RCM, CVI
R412019686		PRA, SSI, GSU, RTC, CKP, GPC, MSC, MSN, RCM, CVI
R412019493		PRA, SSI, GSU, RTC, CKP, GPC, MSC, MSN, RCM, CVI
R412019687		PRA, SSI, GSU, RTC, CKP, GPC, MSC, MSN, RCM, CVI

Part No.	Type of contact	Cable length L	Min./max. DC operating voltage
R412019490	Reed	0.3 m	5 ... 30 V DC
R412019686	Reed	0.5 m	5 ... 30 V DC
R412019493	electronic PNP	0.3 m	10 ... 30 V DC
R412019687	electronic PNP	0.5 m	10 ... 30 V DC

Part No.	Voltage drop U at I _{max}	DC switching current, max.
R412019490	≤ 0,5 V	0.13 A
R412019686	≤ 0,5 V	0.13 A
R412019493	≤ 2,5 V	0.1 A
R412019687	≤ 2,5 V	0.1 A

Part No.	AC switching current, max.	Switching capacity
R412019490	0.13 A	3 W / 3 VA

Part No.	AC switching current, max.	Switching capacity
R412019686	0.13 A	3 W / 3 VA
R412019493	-	-
R412019687	-	-

Part No.	Version
R412019490	Protected against polarity reversal
R412019686	Protected against polarity reversal
R412019493	short circuit resistant Protected against polarity reversal
R412019687	short circuit resistant Protected against polarity reversal

Technical information

The max. switching capacity must not be exceeded.

Technical information

Material	
Housing	Polyamide fiber-glass reinforced
Cable sheath	Polyurethane

Dimensions

Dimensions

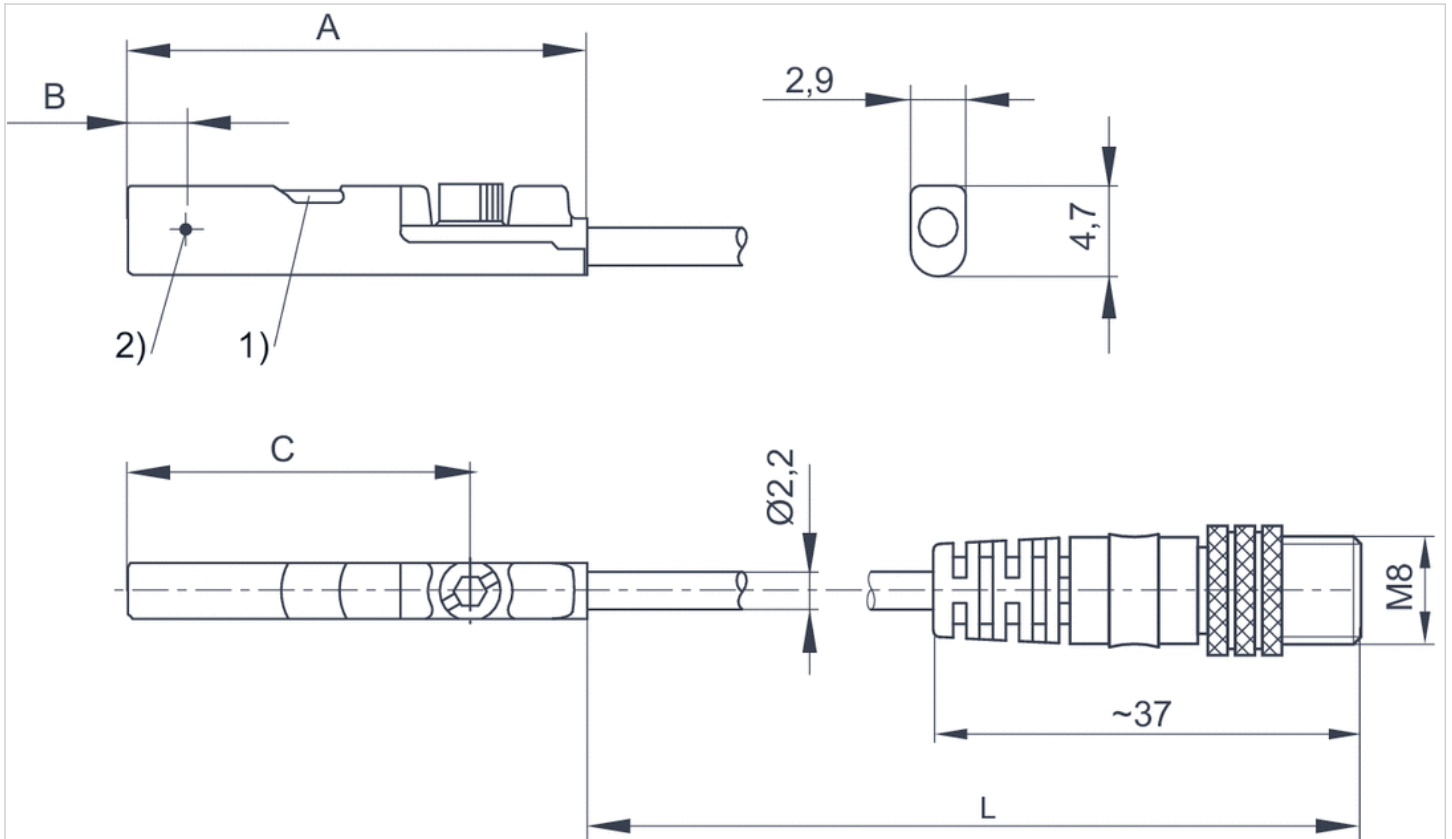

1) LED 2) Switching point
L = cable length

Dimensions

Part No.	A	B	C
R412019490	26.3	6.3	20.3
R412019686	26.3	6.3	20.3
R412019493	23.7	2.8	17.7
R412019687	23.7	2.8	17.7

Pin assignments

Pin assignments

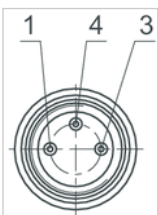

Pin	1	3	4
Allocation	(+)	(-)	(OUT)

Sensor, Series ST4

- 4 mm T-slot
- with cable
- Plug, M8, 3-pin
- UL certification
- Reed electronic PNP electronic NPN
- Direct mounting for series PRA, SSI, GSU, RTC, CKP, GSP, MSC, MSN, RCM, CVI
- Indirect mounting for series MNI, CSL-RD, ICM



Certificates	UL (Underwriters Laboratories) cULus RoHS
Ambient temperature min./max.	-30 ... 80 °C
Protection class	IP65, IP67
Switching point precision	±0,1 mT
Min./max. DC operating voltage	See table below
Switching logic	NO (make contact)
Display	LED
LED status display	Yellow
Vibration resistance	10 - 55 Hz, 1 mm
Shock resistance	30 g / 11 ms
Cable length L	0.3 m
Mounting screw	Combination: slotted and hexagon socket

Technical data

Part No.		for
R412019682		PRA, SSI, GSU, RTC, CKP, GSP, MSC, MSN, RCM, CVI
R412019683		PRA, SSI, GSU, RTC, CKP, GSP, MSC, MSN, RCM, CVI
R412019694		PRA, SSI, GSU, RTC, CKP, GSP, MSC, MSN, RCM, CVI

Part No.	Type of contact	Cable length L	Min./max. DC operating voltage
R412019682	Reed	0.3 m	5 ... 30 V DC
R412019683	electronic PNP	0.3 m	10 ... 30 V DC
R412019694	electronic NPN	0.3 m	10 ... 30 V DC

Part No.	Voltage drop U at I _{max}	DC switching current, max.
R412019682	≤ 0,5 V	0.13 A
R412019683	≤ 2,5 V	0.1 A
R412019694	≤ 2,5 V	0.1 A

Part No.	AC switching current, max.	Switching capacity
R412019682	0.13 A	3 W / 3 VA
R412019683	-	-
R412019694	-	-

Part No.	Version
R412019682	Protected against polarity reversal
R412019683	short circuit resistant Protected against polarity reversal
R412019694	short circuit resistant Protected against polarity reversal

Technical information

The max. switching capacity must not be exceeded.

Technical information

Material	
Housing	Polyamide fiber-glass reinforced
Cable sheath	Polyurethane

Dimensions

Dimensions

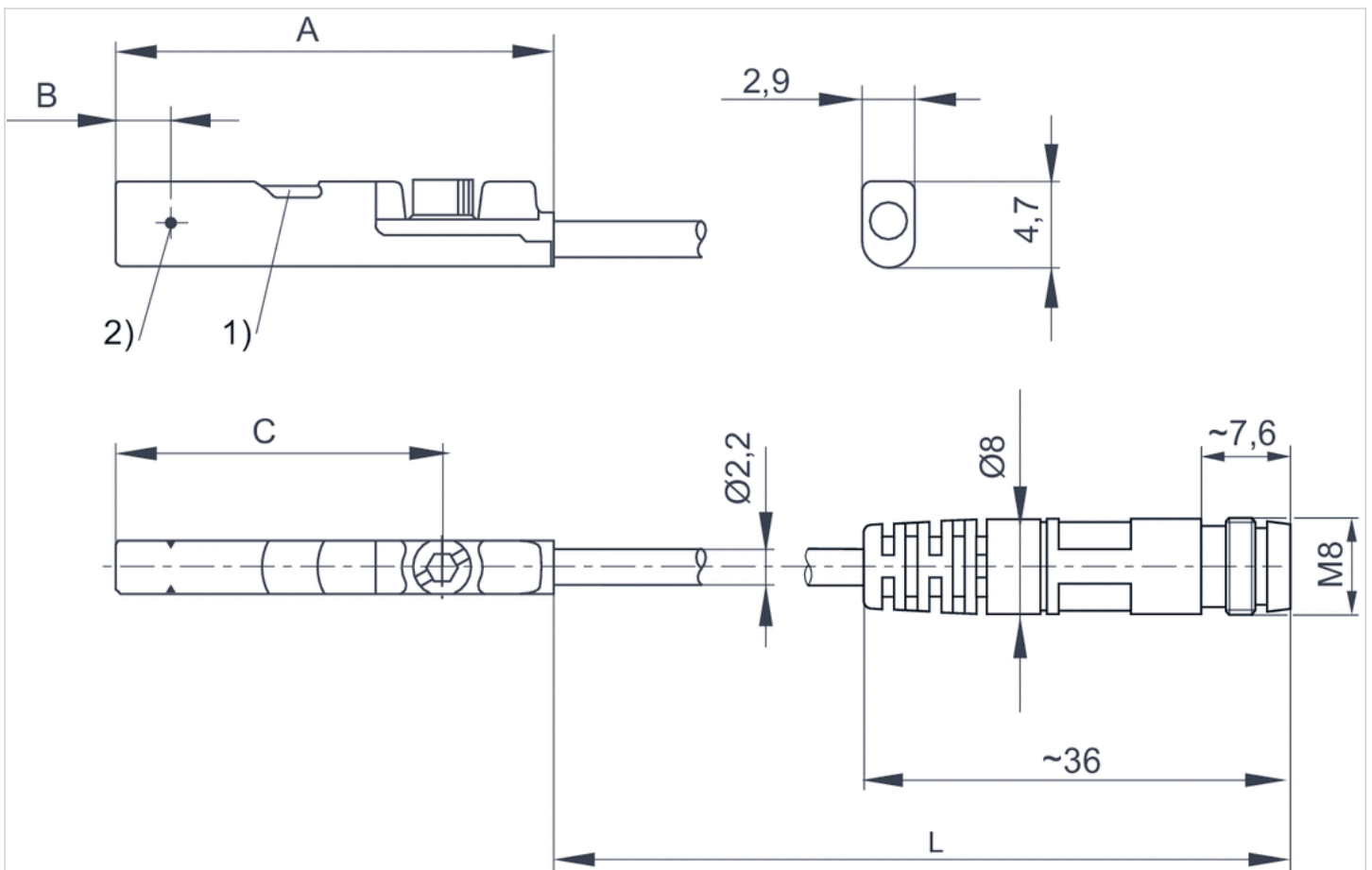

1) LED 2) Switching point
L = cable length

Dimensions

Part No.	A	B	C
R412019682	26.3	6.3	20.3
R412019683	23.7	2.8	17.7
R412019694	23.7	2.8	17.7

Pin assignments

Pin assignments

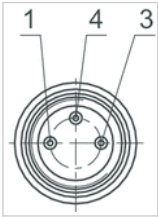

Pin	1	3	4
Allocation	(+)	(-)	(OUT)

Sensor, Series ST4

- 4 mm T-slot
- with cable
- open cable ends, 3-pin
- UL certification
- Reed electronic PNP electronic NPN
- Direct mounting for series PRA, SSI, GSU, RTC, CKP, GPC, MSC, MSN, RCM, CVI
- Indirect mounting for series MNI, CSL-RD, ICM



Certificates	UL (Underwriters Laboratories) cULus RoHS
Ambient temperature min./max.	-30 ... 80 °C
Protection class	IP65, IP67
Switching point precision	±0,1 mT
Min./max. DC operating voltage	See table below
Switching logic	NO (make contact)
Display	LED
LED status display	Yellow
Vibration resistance	10 - 55 Hz, 1 mm
Shock resistance	30 g / 11 ms
Cable length L	3 5 m
Mounting screw	Combination: slotted and hexagon socket

Technical data

Part No.		for
R412019488		PRA, SSI, GSU, RTC, CKP, GPC, MSC, MSN, RCM, CVI
R412019489		PRA, SSI, GSU, RTC, CKP, GPC, MSC, MSN, RCM, CVI
R412019680		PRA, SSI, GSU, RTC, CKP, GPC, MSC, MSN, RCM, CVI
R412019681		PRA, SSI, GSU, RTC, CKP, GPC, MSC, MSN, RCM, CVI
R412019684		PRA, SSI, GSU, RTC, CKP, GPC, MSC, MSN, RCM, CVI
R412019685		PRA, SSI, GSU, RTC, CKP, GPC, MSC, MSN, RCM, CVI

Part No.	Type of contact	Cable length L	Min./max. DC operating voltage
R412019488	Reed	3 m	5 ... 30 V DC
R412019489	Reed	5 m	5 ... 30 V DC
R412019680	electronic PNP	3 m	10 ... 30 V DC
R412019681	electronic PNP	5 m	10 ... 30 V DC
R412019684	electronic NPN	3 m	10 ... 30 V DC
R412019685	electronic NPN	5 m	10 ... 30 V DC

Part No.	Voltage drop U at I _{max}	DC switching current, max.
R412019488	≤ 0,5 V	0.13 A
R412019489	≤ 0,5 V	0.13 A
R412019680	≤ 2,5 V	0.1 A
R412019681	≤ 2,5 V	0.1 A

Part No.	Voltage drop U at I _{max}	DC switching current, max.
R412019684	≤ 2,5 V	0.1 A
R412019685	≤ 2,5 V	0.1 A

Part No.	AC switching current, max.	Switching capacity
R412019488	0.13 A	3 W / 3 VA
R412019489	0.13 A	3 W / 3 VA
R412019680	-	-
R412019681	-	-
R412019684	-	-
R412019685	-	-

Part No.	Version
R412019488	Protected against polarity reversal
R412019489	Protected against polarity reversal
R412019680	short circuit resistant Protected against polarity reversal
R412019681	short circuit resistant Protected against polarity reversal
R412019684	short circuit resistant Protected against polarity reversal
R412019685	short circuit resistant Protected against polarity reversal

Technical information

The max. switching capacity must not be exceeded.

Technical information

Material	
Housing	Polyamide fiber-glass reinforced
Cable sheath	Polyurethane

Dimensions

Dimensions

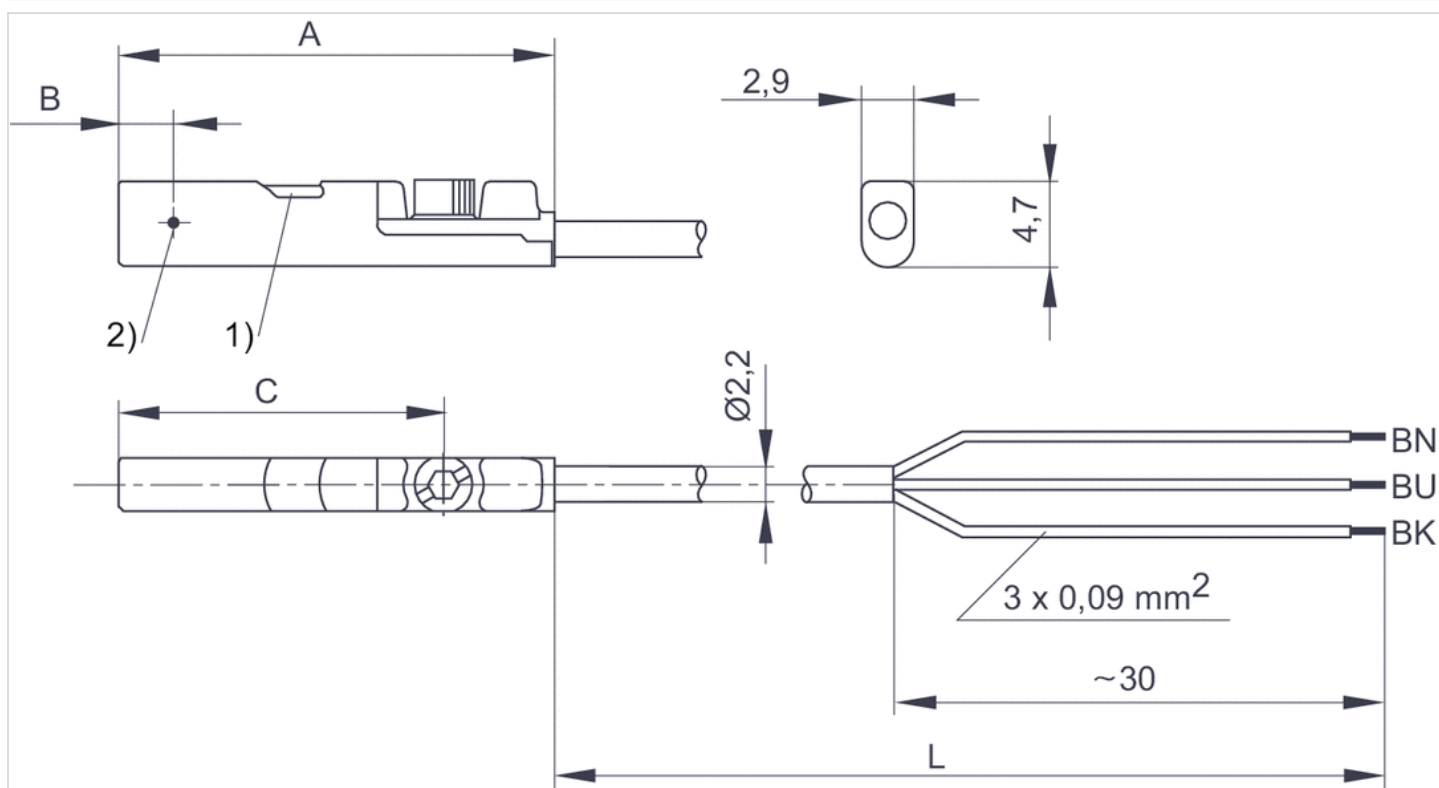

1) LED 2) Switching point

L = cable length

BN = brown, BK = black, BU = blue

Dimensions

Part No.	A	B	C
R412019488	26.3	6.3	20.3
R412019489	26.3	6.3	20.3
R412019680	23.7	2.8	17.7
R412019681	23.7	2.8	17.7
R412019684	23.7	2.8	17.7
R412019685	23.7	2.8	17.7

Kit for shock absorber end stop adjustment

- for series GSU-16 GSU-25

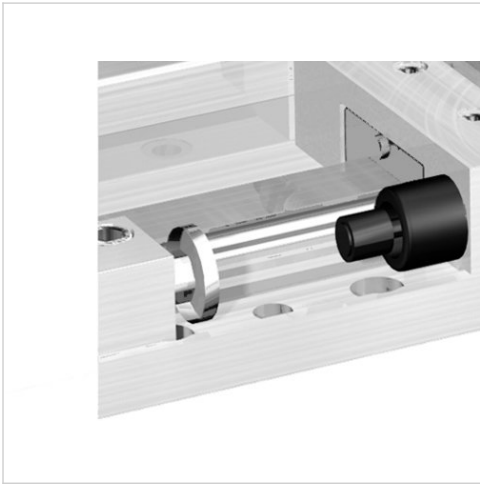

Technical data

Part No.	for series
R402001207	GSU-16
R402001208	GSU-25

The kit contains two stop sleeves and two stop screws. The stop sleeve replaces the mounting nut on the shock absorber.

Efficient pneumatic solutions, our program: cylinders and drives, valves and valve systems, air supply management



Visit us: [Emerson.com/Aventics](https://www.emerson.com/Aventics)

Your local contact: [Emerson.com/contactus](https://www.emerson.com/contactus)



[Emerson.com](https://www.emerson.com)



[Facebook.com/EmersonAutomationSolutions](https://www.facebook.com/EmersonAutomationSolutions)



[LinkedIn.com/company/Emerson-Automation-Solutions](https://www.linkedin.com/company/Emerson-Automation-Solutions)



[Twitter.com/EMR_Automation](https://twitter.com/EMR_Automation)

An example configuration is depicted on the title page. The delivered product may thus vary from that in the illustration. Subject to change. This Document, as well as the data, specifications and other information set forth in it, are the exclusive property of AVENTICS GmbH. It may not be reproduced or given to third parties without its consent. Only use the AVENTICS products shown in industrial applications. Read the product documentation completely and carefully before using the product. Observe the applicable regulations and laws of the respective country. When integrating the product into applications, note the system manufacturer's specifications for safe use of the product. The data specified only serve to describe the product. No statements concerning a certain condition or suitability for a certain application can be derived from our information. The information given does not release the user from the obligation of own judgment and verification. It must be remembered that the products are subject to a natural process of wear and aging.

The Emerson logo is a trademark and service mark of Emerson Electric Co. Brand logotype are registered trademarks of one of the Emerson family of companies. All other marks are the property of their respective owners. © 2017 Emerson Electric Co. All rights reserved.
2019-03



CONSIDER IT SOLVED™